



Development of Double Mould Vibration– Compactor Block Moulding Machine for Developing Countries

**I. T. Adejugbe^{1*}, O. K. Ukoba^{1,2}, A. S. Idowu², A. T. Oyelami²,
and S. O. O. Olusunle²**

¹Department of Mechanical Engineering, Federal University of Technology, Akure, Nigeria.
²Engineering Materials Development Institute, Akure, Nigeria.

Author's contribution

This work was carried out in collaboration between all authors. Authors ITA and OKU designed the Machine using Two (2) CAD Software called the AutoCAD and pro engineer and simulations which were done to show the force analysis of the Machine. Author ITA came up with the manuscript. Author ATO approved the design and simulation of the machine. All authors read and approved the final manuscript.

Article Information

DOI: 10.9734/PSIJ/2014/5813

Editor(s):

- (1) Tienfuan Kerh, National Pingtung University of Science and Technology, Taiwan.
- (2) Xi Wu, Mechanical Engineering Department, California Polytechnic State University, USA.
- (3) Stefano Moretti, School of Physics & Astronomy, University of Southampton, UK.

Reviewers:

- (1) Anonymous, University of Ilorin, Nigeria.
- (2) Anonymous, University of Florida, USA.
- (3) Anonymous, Harran University, Turkey.

Peer review History: <http://www.sciencedomain.org/review-history.php?iid=638&id=33&aid=6071>

Original Research Article

Received 3rd July 2013
Accepted 29th November 2013
Published 11th September 2014

ABSTRACT

This work looked at the design and manufacturing of a low cost and easy to maintain vibration-compaction block moulding machine that can accommodate two different sizes of mould 9 inch (0.46×0.23×0.22m) and 6 inch blocks(0.46×0.15×0.22m). It is borne out of the desire to solve housing problem in developing countries through reduction in the

cost of the building materials like the block. It was designed to compact sandcrete block with strength of 0.99N/mm² which is the same as those made from the universal block making machines but performed better when water absorption was less than 7%. It can produce about 400 blocks in an 8hours working day. It therefore occupies about 1/3rd the space taken and cost of N50,000 which is ¼ of the price of Universal Block Maker. The Vibrator Compactor Block Moulding Machine (VCBMM) was also used to produce sandcrete blocks which had a strength of 0.95N/mm when tested. The water absorption tests carried out on the sandcrete blocks absorbed 6.5 times more water. Therefore, the use of the sandcrete blocks from the VCBMM is recommended for use in all regions. The VCBMM was designed to be highly versatile and to be power driven by diesel motors. Provision was made on the sandcrete mould for sliding plates to be introduced into the mould holes so that 6 inch blocks and 9inch blocks are produced interchangeably.

Keywords: Mould; block; vibration; compactor; machine.

1. INTRODUCTION

Sandcrete block is the most important building material in Africa used in for walls and foundations of buildings. As a material for walls, its strength is less than that of clay bricks but sandcrete is much cheaper. Sandcrete blocks comprise of natural sand, water and binder. Cement, as a binder is the most expensive ingredient in the production of this sandcrete vibrated blocks. This has necessitated producers of sandcrete blocks to produce blocks with low OPC content and will be affordable to people and with much gain.

The poverty level amongst West African countries and particularly Nigeria has made this blocks widely acceptable among the populace so as to minimize the cost of construction works. Manufacturers of the Vibration – Compactor Block Moulding Machine have previously produced just a single mould with the Moulding Machine just a producer of a certain size of block hence the need for a Double Mould Vibration – Compactor Block Moulding Machine to reduce the cost of acquiring two machines. The previous machines in use have had problems with their compressive strength affecting the strength of the sandcrete blocks hence the need to produce a machine with a high compressive strength and a more compact sandcrete block. The need for this machine arose because Engineering is all about making life easier for the Society and this what this machine is all about, a need to reduce the cost of blocks. The cost of a single block depending on its size has reduced because with this machine, the different sizes of block can be produced by just interchanging the mould box and the ramming rods that are produced to work with each other. This has also enabled the producers of this block making machine to meet up with the demands of their customers thus increase their standard of living.

The problem of affordable housing has been a source of concern to all and sundry especially in developing countries where majority of them live below \$1 per day. Shelter represents one of the most basic needs of man and has no doubt a profound impact on the health, welfare and productivity of the individual, and by extension the state. Every Nigerian deserves a roof over his head. The cost of housing can be reduced through reduction in the cost of the building materials. In developing countries like Nigeria, the block is a vital material in building construction as no construction is possible without bricks. Since many centuries, block making has been practiced by human beings. Presently, bricks are easily made by using machines with new technologies. Generally two types of bricks are manufactured by using machines that are concrete block machines and clay block machines.

The aim of the work is to develop a Low Cost Interchangeable Block Moulding Machine that can accommodate the two different sizes of sandcrete blocks. This is a unique design because it can accommodate the different dimensions of sandcrete mold for block making.

The main objective of this project is to design a new Double Mould Vibration – Compactor Block Moulding Machine with new features and simplifying the machine for one man operation in order to reduce operational cost and maximize the production rate. Furthermore, the purpose of this is to design the Double Mould Vibration – Compactor Block Moulding Machine that suitable for SME entrepreneurs [1].

It is believe that a reduction in the cost of the building materials will crash the cost of housing. This machine will be able to produce two different sizes of block and the cost of the machine is very affordable and low compare to imported ones. And the machine can easily be maintained with little or no engineering experience [2].

The efficiency of the machine was reviewed by testing the machine over different environmental conditions. Final valuation was taken from the users of the machine over a period of two (2) weeks. The users of this machine that the data was gotten from are experienced in the use of this machine and they were able to operate this machine with good efficiency. It took a record time of 15secs to produce two (2) blocks unlike the existing that used 26secs to produce the same set of blocks.

2. DESIGN CONSIDERATIONS AND CALCULATIONS

The machine was first designed and modelled using Pro/Engineering software as shown in the diagram and the working drawing taking to the workshop floor for the various manufacturing operation to be perform.

There are Two (2) forces activated in the Machine:

- 1. Compressive Force that will be needed to compress the sand mix in the Mould Box

$$F = mg \dots\dots\dots (1) [3]$$

where *m* = Mass of the HeadRammer = 15kg and

g = accelerationduetogravity = 9.81m/s²

$$F = 15 * 9.81$$

$$= 147.15N$$

- 2. Force due to wet block

$$F = mg \dots\dots\dots (2)$$

$$F_b = Massofwetblock * g [4]$$

Mass of wet block = 27.5kg and *g* = 9.81

$$F_b = 27.5 * 9.81$$

$$F_b = 269.78N$$

Fig. 1 shows the angle of rotation of the ramming handle

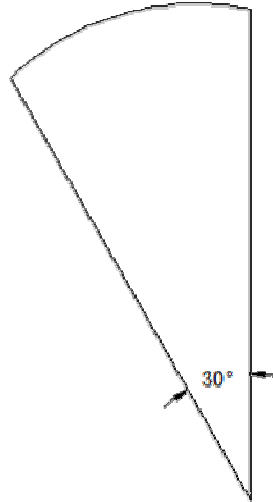

Fig. 1. Angle of rotation of the ramming handle
 ** The wet block is 18% heavier than the dry block [5]

Below is a list of the parameters calculated for and its values.

Parameter	Value
1. Compressive force (F)	147.15
2. Length of the Handlever (r)	1.1m
3. Torque (τ)	80.93Nm
4. Pressure for Compression (P)	420.43Pa
5. Area of Compression (A)	0.35m ²
6. Hopper Volume	0.027025m ³
7. Length of Hopper	0.47m
8. Breadth of Hopper	0.23m
9. Height of Hopper	0.25m
10. Mass of the Mix	36.484kg
11. Density of the Mix (ρ_m)	1350 kg/m ³
12. Volume of the Mix (V)	0.027025m ³
13. Operating STress (σ)	148.1kN/m ²
14. Force of Wet Block (F_{wb})	269.78kN
15. Area of Compact drive shaft	0.001809557m ²
16. umber of Revolution in RPM (N)	1800
17. Power	745.7

Fig. 2 shows the Length of the hopper and the different views of the Hopper.

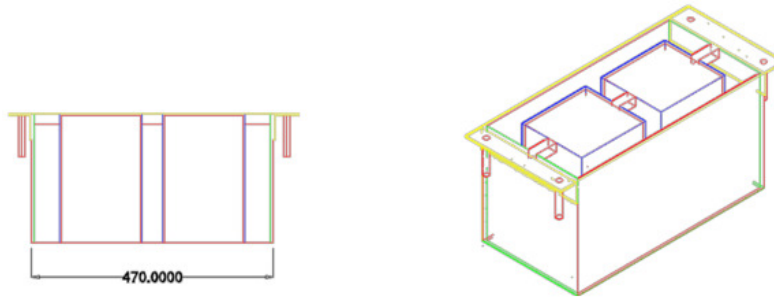

Fig. 2. Cad plot showing the hopper length and 3D view

Operating Stress (σ);

$$\begin{aligned} \sigma &= \frac{\text{Force of Wet Block}}{\text{Area of Compact drive shaft}} \\ \sigma &= \frac{F_{wb}}{\pi \cdot (D_{c ds})^2} \\ \sigma &= \frac{269.78}{\pi \cdot (0.024)^2} \\ \sigma &= \frac{269.78}{0.001809557} \\ \sigma &= 148.1 \text{KN/m}^2 \end{aligned}$$

2.1 Diameter of Eccentric Weight and Compactor Drive Shaft (c ds)

The Compactor drive shaft carried the weight of wet brick mix in bending under minimum tension with a combined shock and fatigue of 1.5 [3]. The drive torque, T, was given in,

$$P = \frac{P * 60}{2\pi N}$$

Where

P = Power rating of the prime mover
N = Number of revolution in rpm

$$P = \frac{745.7 * 60}{2\pi * 1800}$$

$$P = \frac{44742}{11309.73}$$

$$P = 3.96 \text{Nm}$$

The cds in bending was expressed as;

$$(m_{wb} * g * r_s) * 1.5 = 3.96$$

Where r_s = radius of cds

$$r_s = \frac{3.96}{(27.5 * 1.2) * 9.81 * 1.5}$$

$$r_s = \frac{3.96}{485.595}$$

$$r_s = 0.0082m$$

For the Eccentric Weight,

$$r_e = 2r_s$$

$$r_e = 2 * 0.0082$$

$$r_e = 0.0164m$$

r_e is the radius of the eccentric weight, given wet brick mix as 18% heavier than dry brick of weight 27.1kg. Chose $r_e = 0.0165m$ [6].

Hence, the design diameters of the cds and eccentric weight were 16.4mm and 33mm respectively.

3. CONCLUSION

This work has actually gone within the limits of its scope to design and fabricate a Double Mould Vibration – Compactor Block Moulding Machine for small scale indigenous Sandcrete Vibrated Block Industry through the historical development of the VCBMM and the sand mix preparation processes. This design analysis, material selection, construction, maintenance and performance evaluation of the machine was also checked. The machine is simple and designed in such a way that it can be easily transported from one building site to another by careful selection of durable and locally sourced raw materials for its fabrication. As a result of this, the cost of maintenance is low and it's all at a reduced cost for the small and medium scale entrepreneurs.

The following objectives of this work have been considerably achieved, as we have been able to:

- a. Reduce the time spent on sandcrete block production as it takes 8 working hours to produce 400 blocks, hence increase the rate of production since it uses approximately 15 secs to produce 2 blocks.
- b. Produce a machine that is easy to assemble and disassemble using a mounting support so each unit can be considered separately during maintenance.
- c. Produce a machine that is safe to use by using cover and guard to guard the transmission parts, thereby, protecting the operator from hazards of unguarded rotating parts.

4. LIMITATION

The following Limitations were encountered:

1. Power Failure was continually encountered and as a result led to more production downtime and increase in the cost of fabrication. The amount used for fuel consumption led to an increase in cost of fabrication.

2. There were few challenges in getting the Block Moulding Machine to the End users but this was later achieved with marketing strategies and there is sufficient demand for the Machine.

5. PLANS FOR FURTHER WORK

1. Steps are been taken to increase the efficiency of the Machine
2. Steps have been taken to increase the Number of Molds that the machine can accommodate thus increasing the production capacity of the machine
3. Steps have been taken to make the machine automated and still make it affordable for Small and Medium Entrepreneurs' thus reducing production downtime and make it easy to operate.

Fig. 3 shows the side view of the Modeled Double Mould Vibration Compactor Block Moulding Machine.

Fig 4 shows the 3D view of the double mould vibration compactor block moulding machine

Fig. 5 shows the front view of the Modeled double mould vibration compactor block moulding machine.

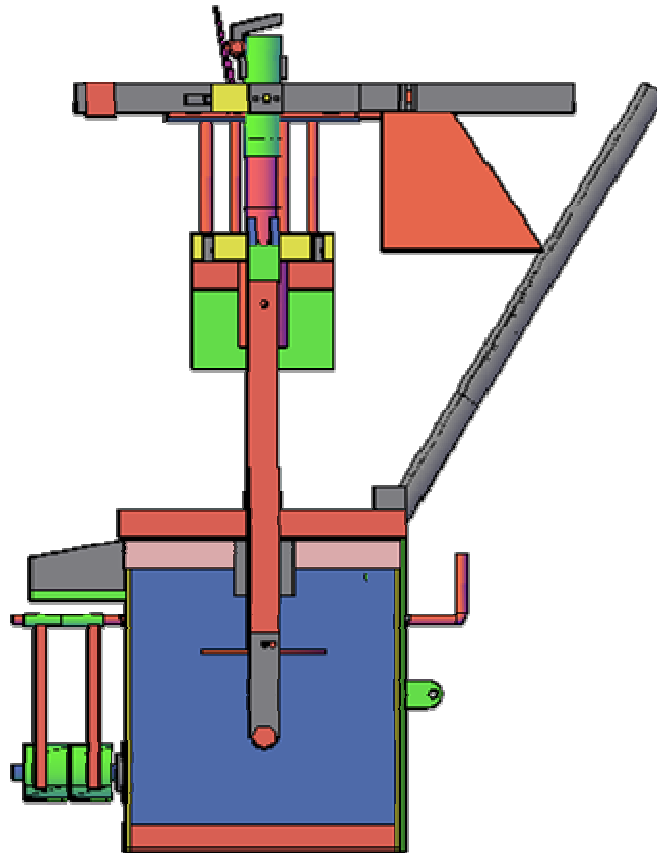

Fig. 3. Side view of the double mould vibration compactor block moulding machine

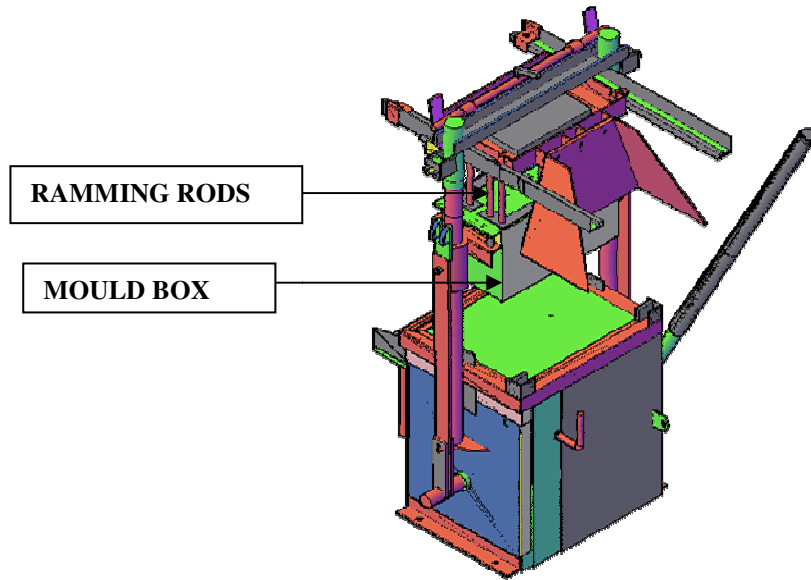

Fig. 4. 3D isometric view of the double mould vibration compactor block moulding machine

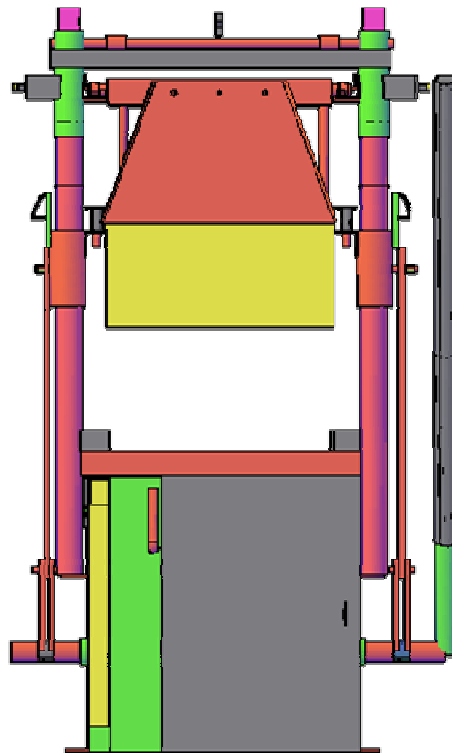

Fig. 5. Front view of the double mould vibration compactor block moulding machine

Fig. 6 shows a picture of the fabricated double mould vibration compactor block moulding machine.

Fig. 7 shows different views of the fabricated double mould vibration compactor block moulding machine.

Fig. 8 shows the Modeled double mould vibration compactor block moulding machine with a 6" Mould.

Fig. 9 shows a 3D view of the modelled Double Mould Vibration Compactor Block Moulding Machine with a 9" Mould

The CAD Plot above shows the Double Mould Vibration Compactor Block Molding Machine accommodating the different sizes of Mould Box. The interchangeability is shown by the different Mould Box and Ramming Head that each of the Mould Box has.



Fig. 6. Picture of the fabricated double mould vibration compactor block moulding machine



Fig. 7. Pictures showing different side views of the double mould vibration compactor block moulding machine (during fabrication)

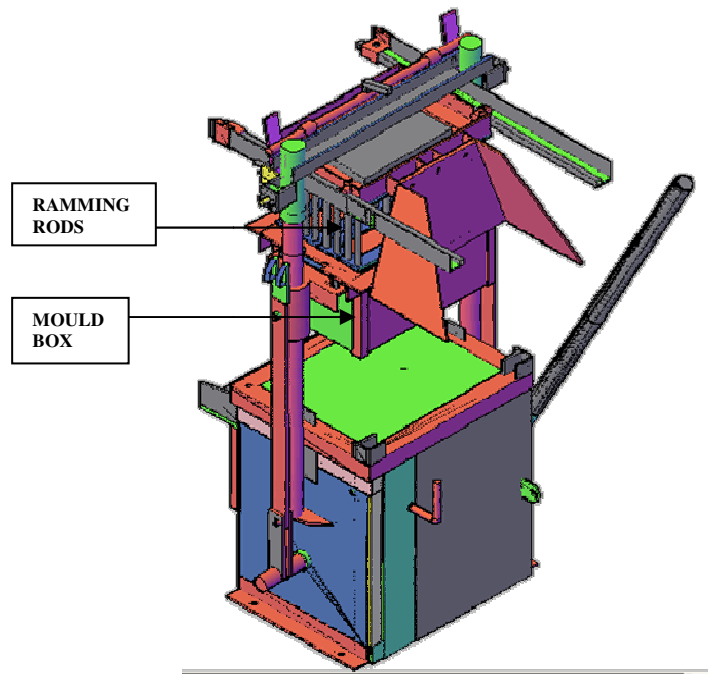

Fig. 8. 6" double mould vibration compactor block moulding machine

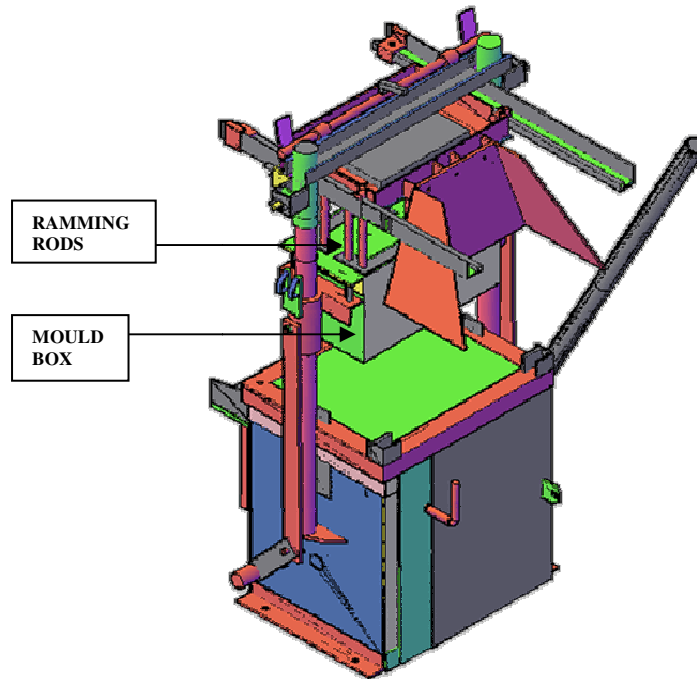

Fig. 9. 9" double mould vibration compactor block moulding machine

CONSENT

All authors declare that 'written informed consent was obtained for publication of this case report and accompanying images. A copy of the written consent is available for review by the Editorial office/Chief Editor/Editorial Board members of this journal.

ACKNOWLEDGEMENTS

We want to acknowledge the contribution of the following staffs of Design, Modeling and Simulation department; Mr. Jolly Osagie, Mr. John Olowonubi, Mr. Femi Oyegunwa and all staffs of EMDI's Workshop. Thanks for all forms of contribution during the design and fabrication of the said machine.

COMPETING INTERESTS

Authors have declared that no competing interests exist.

REFERENCES

1. Murell. Ergonomics, man in his working environment, Chapman and Hall Ltd., London; 1965.
2. Olusegun, Ajiboye. Design, construction and testing of vibrator compactor block making machine for rural application. International Journal of Engineering. 2009;1-14.

3. Khurmi, Gupta. A textbook of machine design, 14th edition. Eurasia Publishing House (PVT) Ltd, Ram Nagar, New Delhi; 2005.
4. Akers, Gassman, Smith. Hydraulic power System Analysis, CRC Press, Taylor and Francis Group, Boca Raton, FL, USA. 2006;23-34.
5. Mogaji. Development and performance evaluation of hydraulic brick moulding machine. Assumption University Journal of Technology Technical Report. 2011;14(4):308-312.
6. Karnopp, Margolis, Rosenberg. System dynamics: A unified approach. John Wiley & Sons, Inc. \$ New York, USA. 1990;45-47.

© 2014 Adejugbe et al.; This is an Open Access article distributed under the terms of the Creative Commons Attribution License (<http://creativecommons.org/licenses/by/3.0>), which permits unrestricted use, distribution, and reproduction in any medium, provided the original work is properly cited.

Peer-review history:

The peer review history for this paper can be accessed here:
<http://www.sciencedomain.org/review-history.php?iid=638&id=33&aid=6071>